



OWS-MIOL-B-XX – MIOL

Medium Intensity Obstruction Light Red/IR

Obstacle light for night time marking of structures that present a hazard to aviation. Red flashing + IR in modes.

Incorporates the benefits of advanced LED, optical and system control technologies to meet the most demanding applications.

Key Features

- Two years warranty
- Smallest light fixture in the industry
- Offshore product design experience
- Compact and Lightweight
- Easy to install
- 100.000 hours design life
- Built-in photocell and monitoring sensors
- Integrated GPS based flash synchronization between lights
- No maintenance required over service life
- Automotive industry standard optical design
- Extremely low power consumption
- Long life power supply to match LED life
- Made in The Netherlands

Performance characteristics

- Horizontal beam pattern: 360°
- Flashing: 20/30/40 FPM
- Effective intensity: 2.000cd red
- Vertical beam pattern: 3° FWHM
- Infra-Red wavelength ~850 nm
- Infra-Red beam follows visible red light



Electrical characteristics

- Operating voltage: 48Vdc
- Power consumption: 20Watt
- Overvoltage protection: Class III according to IEC61643-1 [OPTIONAL]

Physical characteristics

- Dimensions: L x W x H: 365x365x111 mm
- Mounting position: see drawing, page 3
- Mounting: 4x Ø16
- Weight: 7,4 kg
- Design degree of protection: IP66
- Operating temperature range: -25 °C/+60 °C
- Supplied with pre-mounted cables for easy installation and high reliability ready for use (1.5meter)
- Cable bending radius static: 7x cable diameter
- Outer cable diameter: Ø12.5 +/- 0.5 mm
- Level indicators for correct mounting

System design, control and monitoring

- Use as a stand-alone light, or in a multiple light system with an OWS Control system (OWS-CTRLxx)
- Optional OWS Control system facilities provides control interfaces for:
 - "smart switch" aircraft detection input
 - Visibility condition variable intensity input
 - Visibility condition variable intensity input; intensity steps 30% and 10%
 - Remote photocell control input/override



Offshore Warning Systems B.V.

Waldammeweg 7D, 4338 PM, Middelburg, The Netherlands.

KVK: 86564234 | VAT: NL864007577B01

www.offshorewarningsystems.com | tel: +31 6 53316982 | mail: info@owsbv.com

V1.0



Order codes

Configuration table

ORDER CODE	LIGHT PERFORMANCE		
	DAY	TWILIGHT	NIGHT
OWS-MIOL-B-20	OFF	OFF	2.000 cd 20 fpm red & IR
OWS-MIOL-B-30	OFF	OFF	2.000 cd 30 fpm red & IR
OWS-MIOL-B-40	OFF	OFF	2.000 cd 40 fpm red & IR



Offshore Warning Systems B.V.

Waldammeweg 7D, 4338 PM, Middelburg, The Netherlands.

KVK: 86564234 | VAT: NL864007577B01

www.offshorewarningsystems.com | tel: +31 6 53316982 | mail: info@owsbv.com

V1.0



DRAWING

General dimensions

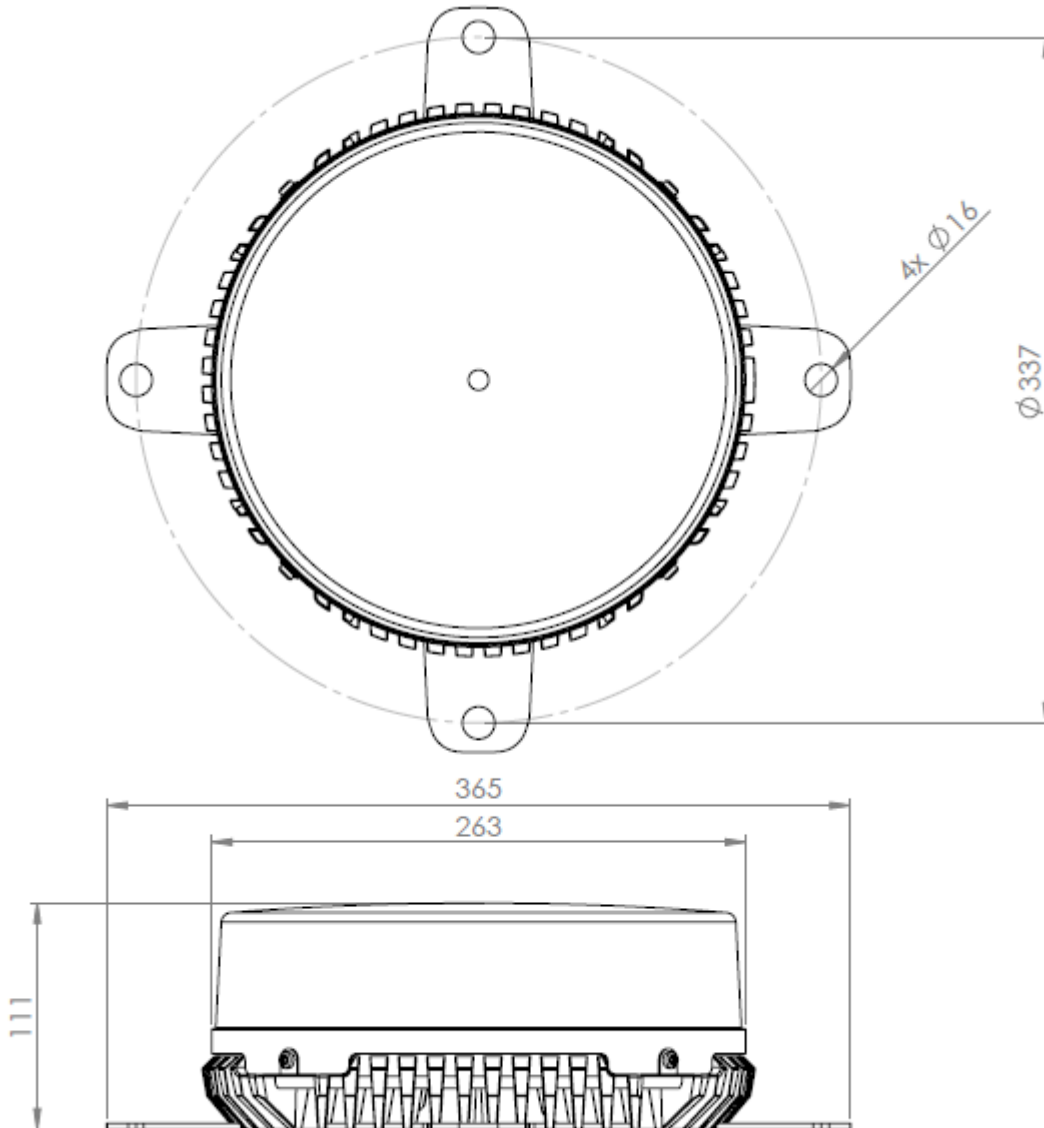

Offshore Warning Systems B.V.

Waldammeweg 7D, 4338 PM, Middelburg, The Netherlands.

KVK: 86564234 | VAT: NL864007577B01

www.offshorewarningsystems.com | tel: +31 6 53316982 | mail: info@owsbv.com

V1.0